

"THE FLOW" SEAL WATER MONITORING AND REGULATION SYSTEM INSTALLATION, START UP AND MAINTENANCE INSTRUCTIONS FOR PACKING OR SINGLE MECHANICAL SEAL

GENERAL

THE SEAL WATER MONITORING AND REGULATION SYSTEM IS A COMPLETE PACKAGE WITH A MOUNTING STAND. IT IS INSTALLED NEAR THE PUMP. EACH APPLICATION INCLUDES FLOW METER, THE NECESSARY HOSES AND CONNECTORS, AND ALSO AN INDUCTIVE LOW FLOW ALARM SENSOR AS AN OPTION.

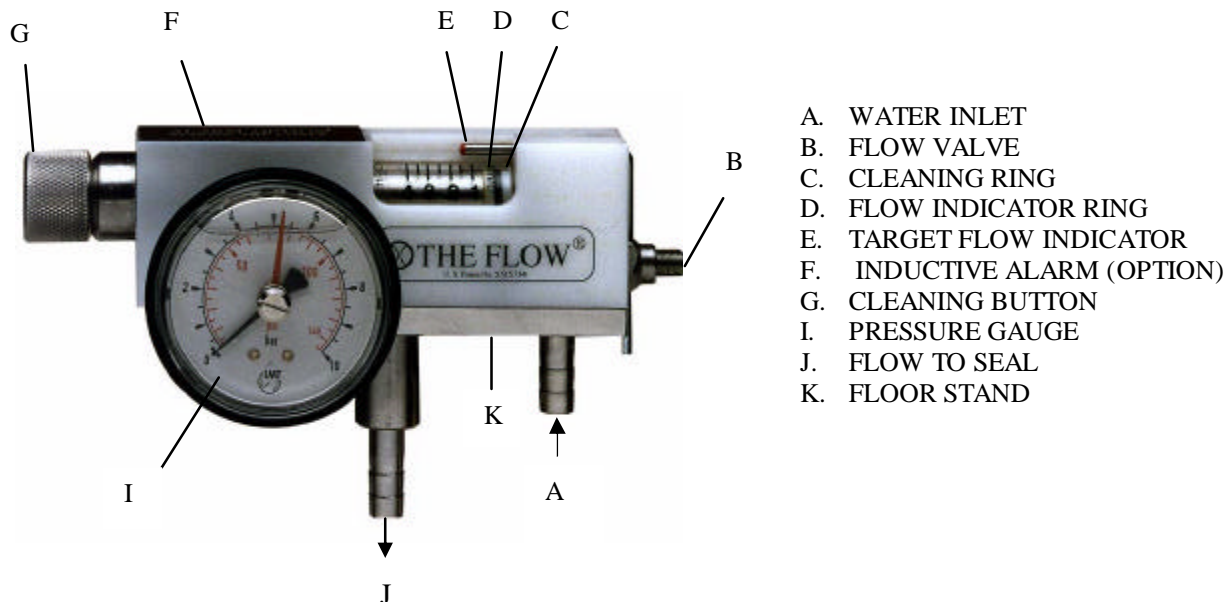

INSTALLATION AND START UP

EACH METER REQUIRES THE FOLLOWING STEPS IN CONNECTION WITH THE START UP. NEW OR RENEWED SEALING WATER LINES NEED TO BE FLUSHED PROPERLY TO PREVENT HARMFUL METAL OR OTHER PARTICLES FROM GETTING TO THE SYSTEM OR THE SEAL.

1. INSTALL THE SYSTEM AT A SUITABLE LOCATION NEAR THE PUMP (SEE THE INSTALLATION DRAWING APPENDIX #1). CONNECT HOSES TO WATER SUPPLY (A), SEAL (J) AS SHOWN.

OPEN THE SEAL WATER LINE VALVE.

2. SET THE TARGET FLOW INDICATOR (E) WITH 2.5 MM HEX KEY TO THE DESIRED TARGET FLOW VALUE BY TURNING THE INDICATOR SCREW ON THE RIGHT SIDE OF THE METER.
3. OPEN THE FLOW VALVE (B). WATER FLOWING THROUGH THE METER WILL MOVE THE WHITE FLOW INDICATOR RING (D) ON THE STAINLESS STEEL FLOAT TOWARD THE LEFT SIDE OF THE METER. THE POSITION OF THE WHITE RING WILL INDICATE THE FLOW RATE. ADJUST THE FLOW VALVE UNTIL THE FLOW RATE MATCHES THE TARGET FLOW RATE (E).
4. SET THE TARGET PRESSURE INDICATOR TO THE DESIRED PRESSURE ON THE PRESSURE GAUGE (I).

5. (OPTION) CONNECT THE ALARM SENSOR (F) WITH THE INSTRUMENTATION ACCORDING TO THE SPECIFICATIONS IN APPENDIX #2, AND MAKE THE LOW FLOW ADJUSTMENT ACCORDING TO APPENDIX #3.

MAINTENANCE AND SPARE PARTS

THE FLOW TUBE AND FLOW CARTRIDGE SHOULD BE CLEANED FEW TIMES A YEAR WITH CLEANING BUTTON (G), SEE APPENDIX #4.

DEPENDING ON THE NUMBER OF SYSTEMS INSTALLED, IT IS RECOMMENDED TO HAVE ONE SPARE SYSTEM ON SITE. IN ADDITION TO THE PARTS LISTED IN THE INSTALLATION DRAWINGS OF DIFFERENT APPLICATIONS, THE FOLLOWING SPARE PARTS FOR THE FLOW METER ARE AVAILABLE.

- FLOW TUBES FOR THE DIFFERENT FLOW RANGES
- FLOW CARTRIDGE (ONE PACKAGE WHICH CONTAINS ALL INTERNALS OF THE METER)
- HEXAGONIAL KEY 2.5MM

APPENDIXES

INSTALLATION DRAWINGS OF THE APPLICATIONS (APPENDIX #1)

TECHNICAL DATA OF THE ALARM UNIT (APPENDIX #2)

ADJUSTING THE ALARM (APPENDIX #3)

CLEANING THE METER INSTRUCTIONS (APPENDIX #4)

SAFETY INSTRUCTIONS (APPENDIX #5)

DECLARATION BY THE MANUFACTURER (APPENDIX #6)

SEAL WATER METER FOR PACKINGS

TFT / W02

PARTS

- | | |
|---|---|
| 1. TFP-08-10-R3/8" -S+(A) OR
TFP-02-145-3/8" NPT-S+(A) | 1 |
| 2. MOUNTING STAND | 1 |
| 3. CHECK VALVE | 1 |
| 4. HOSE FITTING R3/8" OR (3/8" NPT) | 1 |
| 5. HOSE CLAMP P 17-21 | 2 |
| 6. HOSE 3/8" 1,5m | 1 |
| 7. WEDGE LOCKING SCREW 8x75 | 2 |

TFP-08-10 has no pressure valve, flow range from 0 to 8 l/min and pressure range from 0 to 10 bar
 TF-02-145 has no pressure valve, flow range from 0 to 2 gal/min and pressure range from 0 to 145 psi
 (A) is with optional Alarm

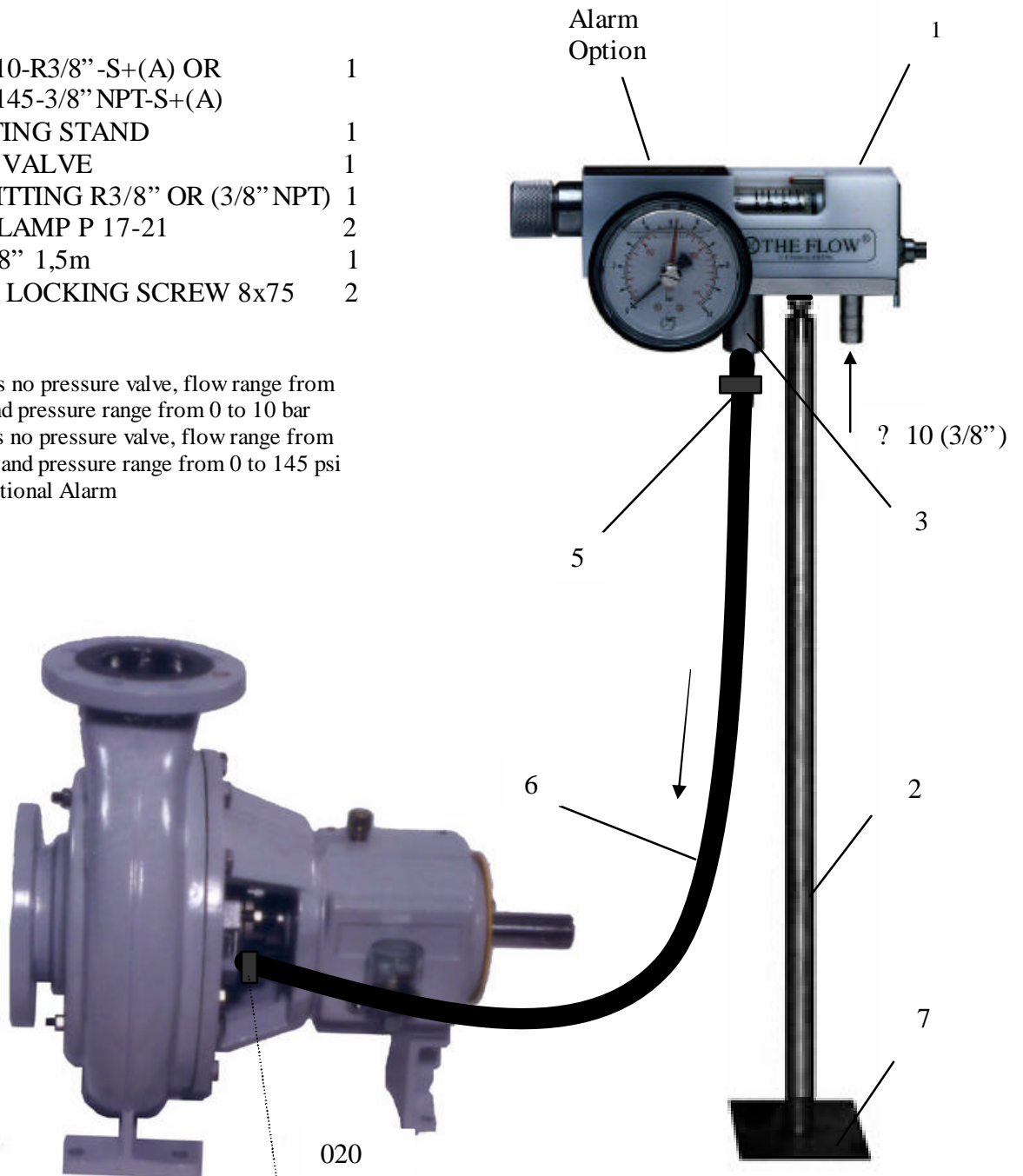

TECHNICAL DATA FOR ALARM SENSOR

Hermetically sealed, inductive switch
 Metal or plastic thread 12x I
 Sensing range 4 mm
 5-year warranty

Electrical design	DC PNP	DC NPN	DC quadronorm	AC
Connection				
Nominal sensing range	4 mm	4 mm	4 mm	4 mm
Output	closed	closed	opened/ closed	closed
Operating voltage	10-36 VDC	10-36 VDC	10-55 VDC	20-250 VAC
Current rating Continuous	250 mA	250 mA	400 mA	250 mA
Current rating Peak	250 mA	250 mA	400 mA	0.9 A (20 ms/0.5Hz)
Minimum load current	-	-	4 mA	8 mA
Voltage drop	< 2.5 V	< 2.5 V	< 4.6 V	< 8.5 V
Leakage current	-	-	< 0.5 mA	<3 mA/250VAC <1.5mA/120VAC
Switching frequency	400 Hz	400 Hz	1500 Hz	25 Hz
Output status indication	yellow	yellow	yellow	yellow
Operating temperature	- 25...+80 C	-25...+80 C	-25...+80 C	-25...+80C
Protection	IP 67	IP 67	IP 67	IP 67
EMC	group 1	group 1	group 1	group 1
Housing material	Plastic, nickel-plated brass or stainless steel			
Connection	PVC cable	PVC cable	PVC cable	PVC cable

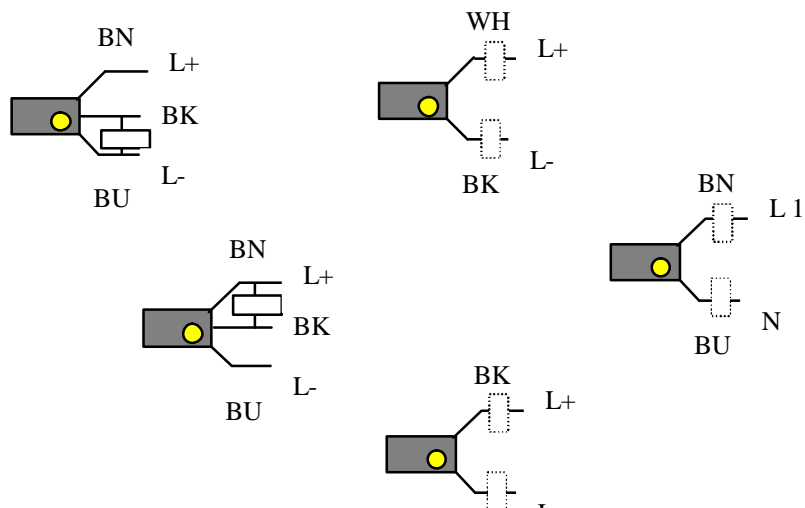
Wiring

ADJUSTING THE LOW FLOW

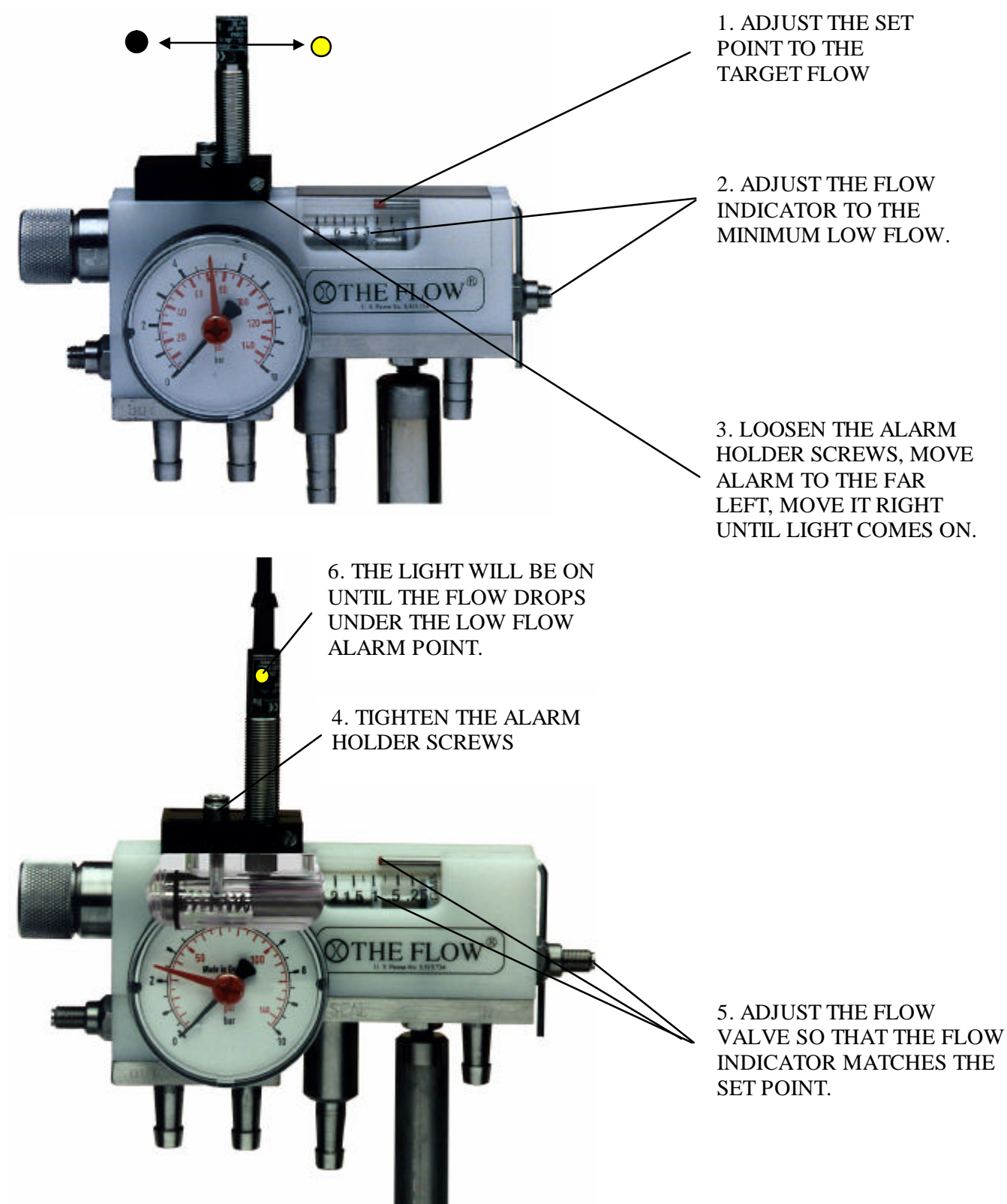

CLEANING THE FLOW

THE ENTIRE FLOW TUBE CAN BE CLEANED WITHOUT DISTURPTING FLOW TO THE SEAL

1. UNSCREW THE FLOW TUBE CLEANING BUTTON WITH YOUR FINGERS

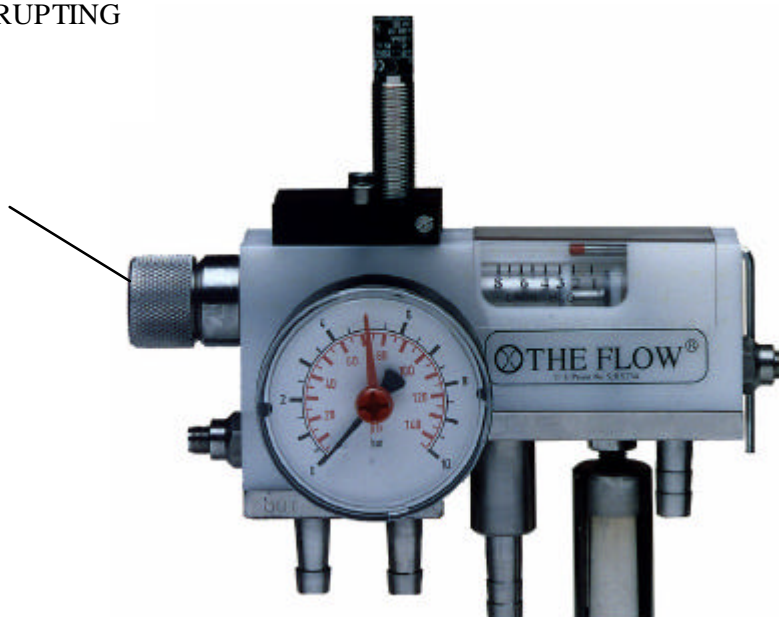

2. MOVE THE BUTTON BACK AND FORTH AND SCREW IT BACK INTO IT'S LOCKED POSITION

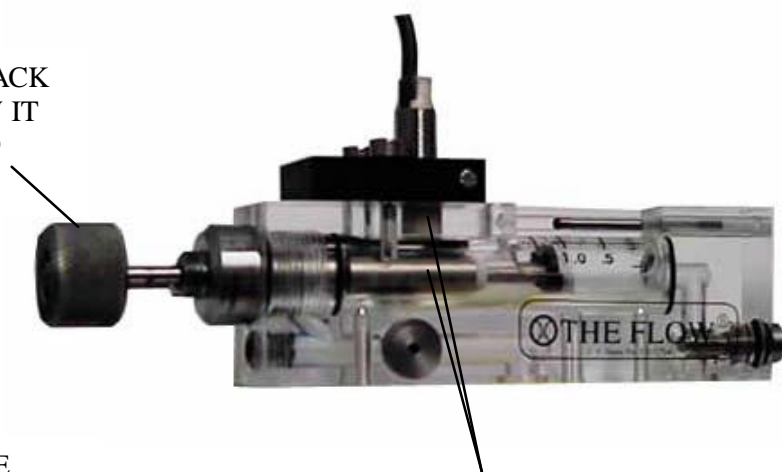

THIS ACTION MOVES THE CLEANING RING BACK AND FORTH THROUGH THE FLOW TUBE SCRAPING IT CLEAN

FLOW AND PRESSURE WILL NOT CHANGE WHILE CLEANING

THE ALARM IS NOT ACTIVATED WHEN FLOW TUBE IS CLEANED. STEEL FLOAT STAYS UNDER THE ALARM SENSOR WHILE CLEANING TAKES PLACE.

Safety instructions for "THE FLOW" seal water regulation and monitoring system.

FOLLOW ALWAYS THE OPERATION AND MAINTENANCE INSTRUCTIONS ENCLOSED IN THE SHIPMENT!

Safety instructions for mounting:

The seal water meter is installed near the pump in the way that it is clearly seen to which pump or seal it is connected. The meter should be mounted so that it is easy to read and maintain.

The seal water meter is mounted firmly to the pump or other solid construction either by using a mounting pipe or a bracket.

Safety instructions for operating:

Before start up check the following things:

- * Check that the meter is correct and properly mounted
 - meter is firmly mounted on a solid construction
 - hoses are not broken and they are properly fasten on correct fittings
- * Check that the flow and pressure ranges of the meter are equal to the requirements of an application.
 - The pressure of seal water must not exceed the highest rate of the pressure gauge
 - The flow of seal water must not essentially exceed the highest rate of the flow scale
- * A broken meter must be repaired or replaced as soon as possible.

Safety instructions for maintenance:

Make sure that all hoses are properly tightened and that there is no leakage. The flow tube and components inside should be cleaned at suitable intervals, e.g. a few times a year by means of the clean up button.

The seal water meter must neither disassembled nor disconnect before seal water has been closed. If there is a need to maintain the meter otherwise than adjust it or clean it by means of the clean up button, the access of seal water must be prevented to the meter.

ATTENTION ! In most cases seal water can not be cut off without shutting down the process.

DECLARATION BY THE MANUFACTURER

(Directive 89 / 392 / EEC, Art. 4.2 and Annex II, sub B)

PROHIBITION TO PUT INTO SERVICE

Manufacturer: THE FLOW TECHNO TFT OY

Address: KORVENKYLÄNTIE 10 40951 MUURAME, FINLAND

Herewith declares that

THIS "THE FLOW" SEAL WATER METER

- is intended to be incorporated into machinery or to be assembled with other machinery to constitute machinery covered by Directive 89 / 392 / EEC, as amended;
- does therefore not in every respect comply with the provisions of this directive;

and furthermore declares that is not allowed to put the machinery into service until the machinery into which it is to be incorporated or of which it is to be a component has been found and declared to be in conformity with the provisions of Directive 89 / 392 / EEC and with national implementing legislation, i.e. as a whole, including the machinery referred to in this declaration.

THE FLOW TECHNO TFT OY

BY: